

承 認 書

SPECIFICATION FOR APPROVAL

客户名称

CUSTOMER

产品名称

PRODUCT NAME

产品型号

MODEL

SPECIFICATION

型	號	
Model	No.	H3-50A
規	格	
Rating		6.3A 250V AC
結 緣 電 阻		
Insulation resistance		DC 500V 100M Ω Min
耐 電 壓		
Voltage breakdown		AC 1500V 1 minute
保 險 絲 規 格		
Fuse size		Φ 5.2 X 20 mm
安 規 認 證		
Approvals		UL VDE

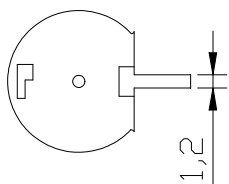
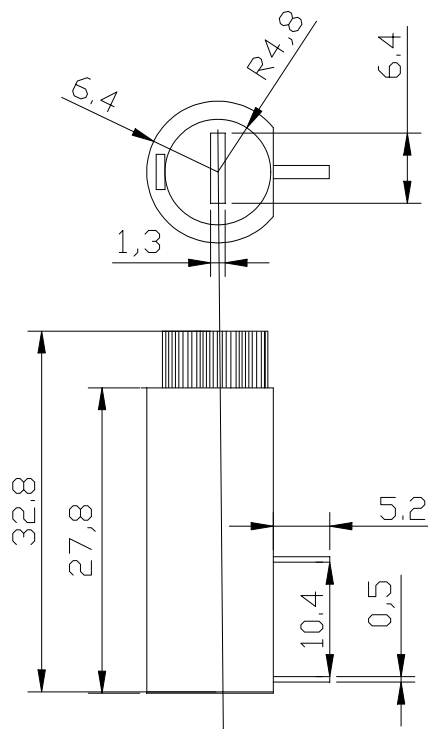

1. 10A 125V AC 6.3A 250V AC
2. $\varnothing 5.2 \times 20$ mm
3. Bayonet type cap
4. PC Board mount terminall
5. P.B.T
6. ul cqc ce vde

	UNIT	mm	保险丝座	QTY.	
	SCALE	1:1			MATL.
DESIGNED			H3-50A	HDN.	
DRAWN				F.SIZE	
CHECKED			海牛电器	FILE	
APPROVED				SHEET	